



**Instruction manual
Of
SJR3-3000 Series
Micro-power Motor Soft Starter with Inbuilt Bypass**



SHUEN, control and protect your motors
SHANGHAI SHUEN ELECTRICAL TECHNOLOGY CO., LTD.

Table of Contents
SJR3-3000 Series Motor Soft Starter

| | |
|---|----|
| 1. Matters before using..... | 1 |
| 1-1 Product overview..... | 1 |
| 1-2 Operation instructions..... | 1 |
| 1-3 Receiving inspection..... | 2 |
| 1-4 Product appearance..... | 2 |
| 2. Service conditions and installation requirements..... | 3 |
| 2-1 Service conditions of the soft starter..... | 3 |
| 2-2 Installation requirements of the soft starter..... | 3 |
| 2-3 connection..... | 4 |
| 2-4 Connection of main circuit and grounding terminal..... | 5 |
| 2-5 Connection diagram for main circuit of SJR3-3000 soft starter..... | 6 |
| 2-6 Connection of control terminals..... | 7 |
| 2-7 Terminal configuration diagrams..... | 8 |
| 2-8 Primary and secondary connection diagram of SJR3-3000 series (three-wire mode)..... | 9 |
| 2-9 Primary and secondary connection diagram of SJR3-3000 series (two-wire mode)..... | 9 |
| 3. Running..... | 10 |
| 3-1 Inspection and preparation before running..... | 10 |
| 3-2 Running method..... | 10 |
| 4. The keyboard panel..... | 11 |
| 4-1 External of the keyboard panel..... | 11 |
| 5. Basic functions..... | 12 |
| 5-1 Code setting function..... | 12 |
| 6. Detailed description of function selection..... | 13 |
| 7. Operation steps..... | 14 |
| 7-1 Modify the set parameters..... | 14 |
| 8. Help information..... | 15 |
| 8-1 Description of help information..... | 15 |
| 9. Protection function..... | 15 |
| 9-1 Description of protection function..... | 15 |
| 9-2 Setting of protection function..... | 16 |
| 9-3 Protective tripping curve..... | 17 |

Table of Contents
SJR3-3000 Series Motor Soft Starter









| | |
|--|----|
| 10. Operated protection..... | 18 |
| 10-1 List of protective actions..... | 18 |
| 11. Troubleshooting..... | 19 |
| 11-1 Problems and solutions..... | 19 |
| 12. Starting mode..... | 20 |
| 12-1 Current limiting starting mode..... | 20 |
| 12-2 Voltage ramp starting mode..... | 20 |
| 12-3 Kick Mode..... | 21 |
| 12-4 Current ramp starting mode..... | 21 |
| 12-5 Voltage and current limiting double closed-loop starting..... | 22 |
| 12-6 Soft stops..... | 22 |
| 12-7 Free stop..... | 22 |
| 13. External dimensions..... | 23 |
| 13-1 External dimensions of 5.5kw_75kw..... | 23 |
| 13-2 External dimensions of 75kw_400kw..... | 24 |
| 14. Application range..... | 25 |
| 14-1 Types of application load..... | 25 |
| 15. RS485 communication..... | 25 |
| 15-1 MODBUS communication protocols..... | 25 |
| 15-2 Relevant settings of the soft starter..... | 26 |
| 15-3 Exception response..... | 28 |
| 15-4 Notes for use..... | 28 |
| 16. Annex..... | 30 |

1. Matters before Using

1-1 Product overview

Thanks for purchasing the "SJR3-3000" series online micro-power consumption motor soft starter of SHANGHAI SHUEN. The company has made further technical improvement in both the software and the structure of the soft starter according to the market demand. With inbuilt bypass contactor the soft starter provides complete motor protection functions including start control, running and overloading, phase failure, three-phase unbalance, over-voltage, under-voltage protection and so on with no need to further install bypass contactor and thermal relay, therefore, as another great achievement in the intelligentization of motor protection and networked technology application, it simplifies the circuit, reduces the volume, cuts the cost, makes installation and using more convenient.

1-2 Operation instructions

-  Be sure to read the operation instructions carefully before installation.
-  The soft starter must be installed by professionals.
-  The specifications of motor must match with the soft starter.
-  Do not connect capacitor to the output terminals (U V W) of the soft starter.
-  The exposed connection terminals must be wrapped with insulating tape.
-  The soft starter and other relevant equipments should be reliably grounded.
-  The input power must be cut off during equipment maintenance.
-  Do not disassemble, modify or repair the product privately.

1-3 Receiving inspection

Upon receiving the equipment you purchased, please unpack to inspect the following items, in the event that there's any problem with the product or the product is not in consistent with the specifications you purchased, please contact with the agent from whom you purchased the equipment or the nearest office of our company.

- 1) Check the name plate in the soft starter and confirm the specifications you purchased.

| | |
|----------------------------------|---|
| Specifications name plate | SJR3-3000 Series Motor Soft Starter Model: SJR3-3075 Input voltage: AC380V 50Hz Rated operational current: 150A Manufacturing number: Manufacturing date: |
| | SHANGHAI SHUEN ELECTRICAL TECHNOLOGY CO., LTD. |

Model of the soft starter

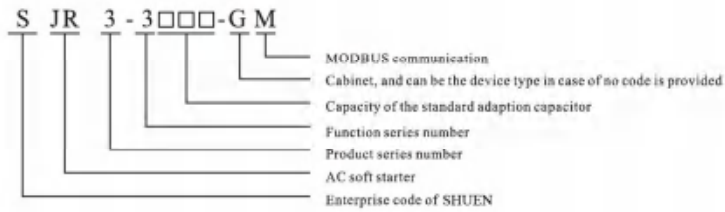

- 1) Check for damages during transportation, such as bending of the cover and the enclosure, damage or missing of parts and components and so on;
- 2) An operation instruction and a compliance certificate shall be attached with the soft starter.
- 3) When moving the soft starter, lift its frame instead of the circuit board control box otherwise falling damage or personal injury may be caused.

1-4 Product appearance



2. Service conditions and installation requirements

For SJR3-3000 series soft starter, the following service conditions and installation requirements should be followed, otherwise, the performance shall not be ensured, and in severe cases, the life-loss or even damage of the soft starter will be caused.

2.1 Service conditions of the soft starter:

Power supply: three-phase AC 380V or 660V \pm 15%, 50 Hz or 60 Hz commercial power, private power station or diesel generator set, the power capacity must meet the soft starter's starting requirements on motor.

Applicable motor: three phase squirrel-cage asynchronous motor, the rated power of the motor should match that of the soft starter.

Start frequency: no requirements, the specific frequency shall be depended on the loading.

Cooling method: natural air cooling.

Protection class: IP20

Environmental conditions: the place with elevation below 3000m, ambient temperature between -25 $^{\circ}$ C—+40 $^{\circ}$ C, relative humidity under 90%, no condensation, no flammable, explosive, corrosive gas, no conductive dust, good ventilation and vibration less than 0.5G.

The company can provide customers with products to be used under special conditions, such as explosion proof type, low temperature type and high pressure type soft starters, service conditions of such starters shall be otherwise indicated.

2.2 Installation requirements of the soft starter:

Installation direction and space: to enable good ventilation and heat dissipating conditions during using of the soft starter, the soft starter should be installed vertically with enough space for heat dissipating left around the equipment. The allowable minimum spaces are shown in figure 2.1 and figure 2.2.

In the event that the soft starter is installed inside the cabinet, besides the above requirements, the cabinet selected should be with good ventilation at the top and bottom, as shown in figure 2.3.

Unit: mm

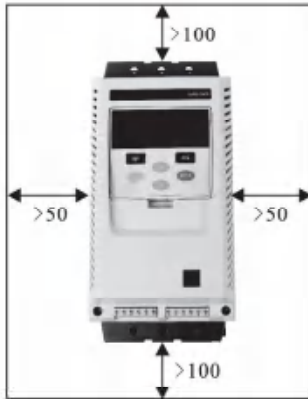

Figure 2.1



Figure 2.2



Figure 2.3

2-3 Connection

Be sure to note all the following instructions during connection. Figure 2-3-1 shows the basic connection.

- a) The power must be connected to the R, S, T power terminals of the main circuit with no requirements in phase sequence. The soft starter will be damaged if the power is mis-connected.
- b) The grounding terminal must be reliably grounded, as it will prevent electric shock or fire alarm accidents as well as reduce noise.
- c) Crimping should be conducted at both ends of the wire to ensure high reliability of connection.

Basic connection diagram

Figure 2-3-1

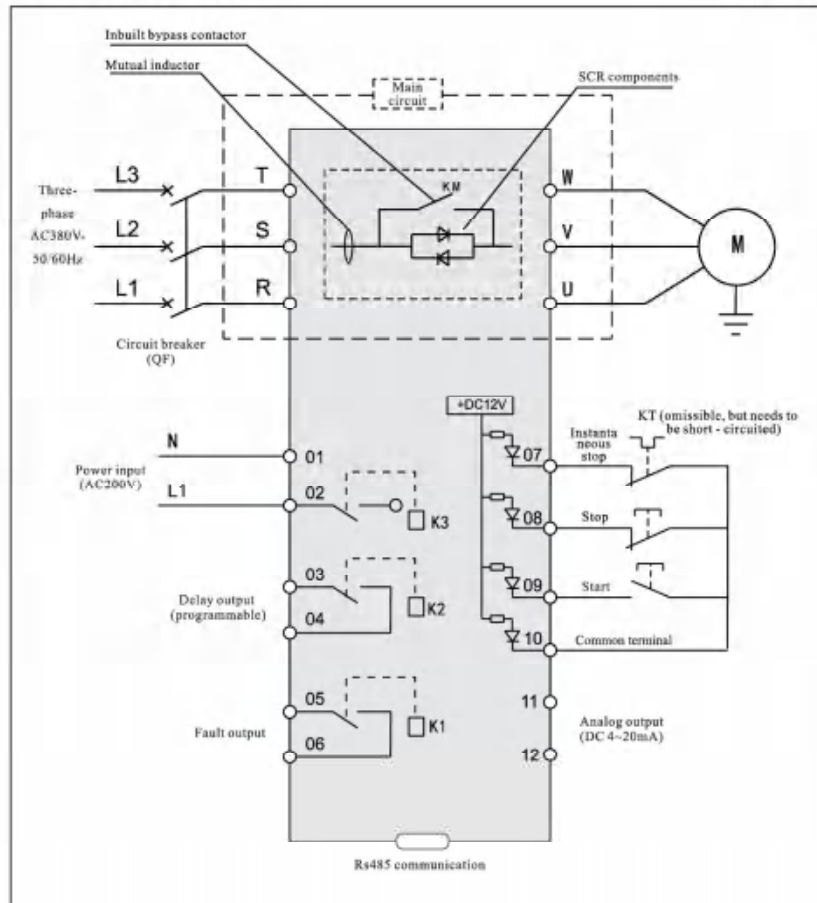

2-4 Connection of the main circuit and the grounding terminal

Table 2-4-1 Functions of the main circuit and the grounding terminal

| Terminal markings | Terminal description | Remarks |
|-------------------|---------------------------------------|---|
| R,S,T | Input of the main circuit power | Connecting three-phase power |
| U,V,W | Output connection of the soft starter | Connecting three-phase motor |
| ⚡ G | Grounding of the soft starter | Grounding terminal of the soft starter cabinet should be reliably grounded. |

- (1) Main circuit power input terminal (R,S,T)
 - a. Connect the main circuit input terminals R, S, T to the three-phase AC power through the circuit breaker for circuit protection or circuit breaker with leakage protection without considering the connection sequence.
 - b. Do not use ON/OFF of the main circuit power to control running and stop of the soft starter, instead, such should be controlled by means of the control terminal or RUN and STOP buttons in the keyboard panel of the soft starter upon power on.
 - c. Do not connect the soft starter to the single-phase power.
- (2) Output terminals of the soft starter (U, V, W)
 - a. Output terminals of the soft starter should be connected to the three-phase motor in correct phase sequence. If the rotation direction of the motor is incorrect, switch connection of any two phases among U, V and W.
 - b. The output end of the soft starter shall not be connected to capacitor or surge absorber.
 - c. If the wire between the soft starter and the motor is very long, the distributed capacitance between the wires will generate high-frequency current which may cause over-current tripping, leakage current increasing and poor current display precision of the soft starter. Therefore, it is suggested that the motor connection wire should be no more than 50m.
- (3) Grounding terminal of the soft starter (⚡ G)
 - a. For safety and noise reducing, the grounding terminal G of the soft starter must be well-grounded. To prevent electric shock and fire accidents, the metal enclosure and frame of the electric equipment should comply with the requirements of the national electronic procedures.

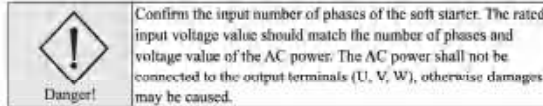

2-5 Connection diagram for main circuit of SJR3-3000 soft starter

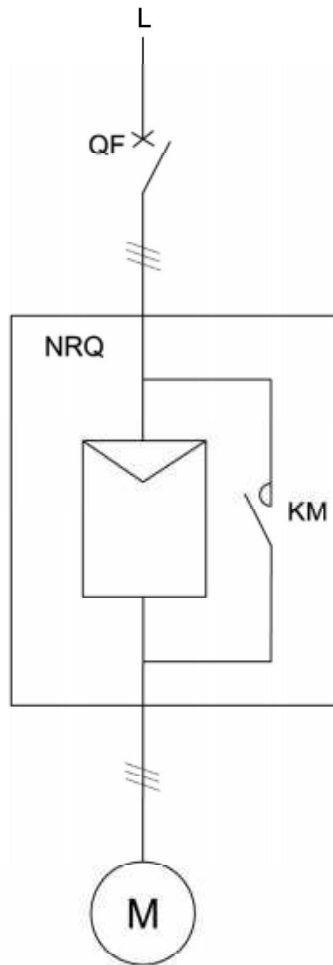

QF circuit breaker

NRQ soft starter with inbuilt bypass

M motor

KM contactor installed inside the soft starter with inbuilt bypass

2-6 Connection of control terminals

Functions of the control circuit terminals are shown in table 2-6-1. Functions and connection of different control terminals vary with different function settings.

Table2-6-1

| Classification | Terminal marking | Terminal description | Function description |
|-------------------------|------------------|---------------------------------|--|
| Connection point output | 01, 02 | Power input | 01, 02 are AC220V power input to the control panel. |
| | 03, 04 | Running output (delay) | 03, 04 are programmable relay output, the delay time is set by the code F4 while the output function time is set by code FE. |
| | 05, 06 | Fault output | 005, 06 are fault relay output, they will be on when there's fault with the soft starter or the power is cut off and be off when the power is on. (capacity of the connection point AC250V/3A) |
| Connection point input | 07 | Instantaneous stop input | The motor will stop immediately when 07 and 10 are disconnected (or be tandemly connected in the normally closed point of the thermal relay) |
| | 08 | Soft stop input | The motor will slow down for soft stop when 08 and 10 are disconnected (or automatically stop). |
| | 09 | Start input | The motor will start for running when 09 and 10 are connected. |
| | 10 | Common terminal | Common terminal for signal input of the connection points |
| Analog output | 11, 12 | Analog output | 11 and 12 are 4~20mA DC analog output which are used to monitor the current of the motor in real time. The maximum value 20mA indicates the current of the motor is four times of the nominal current of the soft starter. 4~20mA DC meter can be connected for observation. Maximum load resistance of this output is 300Ω. |
| Communication | DB | RS485communication input/output | Input and output signal terminal of RS485 communication, can be used to connect several soft starters. |

(1) Input terminals of the connection point

- a) Please set code FB to be external-control valid when the external terminals are used to control the start and stop functions of the soft starter.
- b) Please use (two-wire) control mode when remote control is required, see P9: figure 2-9.
- c) The signal input terminals and common terminal of the connection points are generally operated for ON/OFF, since the soft starter, the motor and wiring will cause interference, therefore, it is suggested to arrange shorter wire (no more than 20m) and use shielded wire as the cable.
- d) Wiring of the control terminals should be kept away from that of the main circuit to the extent possible; otherwise, malfunction may be caused by the interference.

2-7 Terminal configuration diagrams

Terminal diagram of the main circuit

(1) SJR3-3005.5-3075



SJR3-3075-3400



(2) Terminal diagram of the control circuit

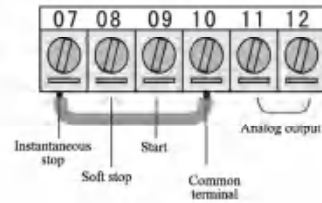
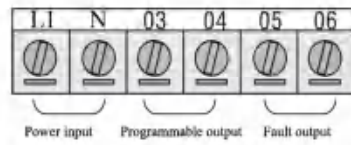

(3) Terminal connection of the control circuit

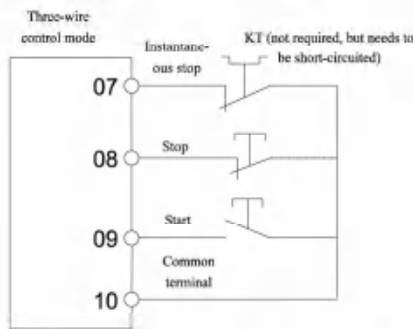

Wire of the control terminals should be 0.75-1.25mm²

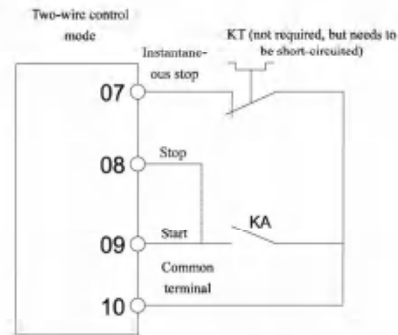

Soft starter will start for running when KA is connected and stop when KA is disconnected.

2-8 Terminal configuration diagrams

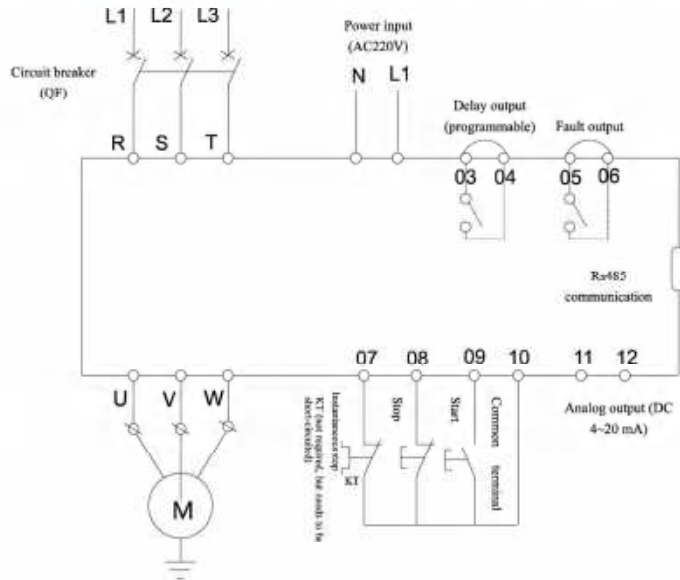

2-9 Terminal configuration diagrams

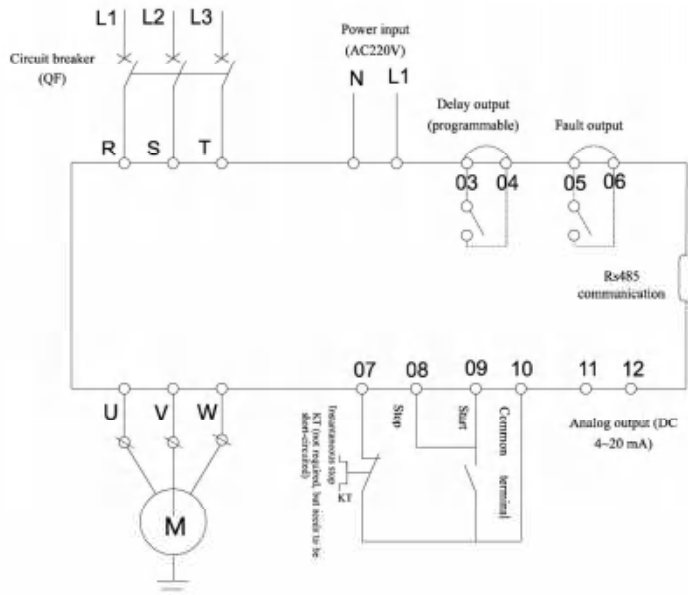

3. Running

3-1 Inspection and preparation before running

The following should be inspected and prepared before starting running:

- (1) Check if the connections are correct or not, particularly, the output terminals should not be connected to the power, and confirm if the grounding terminal is well grounded or not.
- (2) Confirm there's no short circuit or short circuit to earth between the terminals or the exposed live parts.
- (3) Upon the power is connected, the keyboard panel shall display (SHANGHAI SHUEN) or [ready] status.

3-2 Running method

Select appropriate operation method as required, the soft starter is set to be panel controlled when delivery

- Upon the power is connected, the keyboard panel shall display (SHANGHAI SHUEN) or [ready] status, press the start button, the motor will be started.
- Input setting entry *FP* according to the rated current value on the name plate of the motor.
- Upon start, check if the rotation direction of the motor is correct or not, if no, press the stop button to stop the motor or cut off the power if necessary, then switch any two wires of the motor (U,V,W).
- If the motor fails to reach good start status, refer to the section of starting mode and application of the soft starter in page 12 to select proper settings.
- If the torque fails to reach good effect, change the starting voltage code *F0*(under voltage mode) or current limiting code *F5* (under current mode) to increase the start torque of the motor.
- Once power of the soft starter is on, please do not open the cover, otherwise there maybe risks of electric shock.
- In the process of trial running after power on, if there's any abnormal phenomenon, such as abnormal sound, smoke or odor, please cut off the power immediately and find out the causes.
- Press the stop button or external control stop button to reset the fault status.

Note: when the ambient temperature is below -10°C , please get the power on and start the soft starter after preheating for 30mins.

4. Keyboard Panel

4-1 External of the keyboard panel

The keyboard panel contains abundant operation functions, such as running and stop functional data confirmation and change of the keyboard panel and functions of various status confirmation.



Table 4-1-1 functions of the operational buttons

| Button description | Major functions |
|--------------------|--|
| RUN | Press this button to start the soft starter when [ready] status is displayed, meanwhile run status -0000 will be displayed. |
| STOP | 1. When A000 (current value) is displayed in normal running, press this button to stop the motor, -000 will be displayed in soft stop. 2. The button has the function of resetting the fault status. |
| SET | When [ready] status is displayed, press this button to enter menu setting, press this button again when F0: 40 is displayed, the colon will be flashing, then the parameters can be modified through pressing the up or down button. |
| YES | 1. Press this button to save the modified parameter, displaying of "good" with two sounds given out indicate that the data has been saved, then press this button again or the stop button to exit. 2. Press this button to display input power voltage: AC380V 3. Press yes to get the power on, the set parameters will reset to factory defaults. |
| AV | 1. Enter the menu setting to modify parameters (this button will be used to modify the function code when the colon is not flashing and be used to modify the data code when the colon is flashing.) 2. During running, this button can be used for observing the display of the running A current, P power and H overloading heat balance. |

The keyboard panel can be disassembled, (placed outside the cabinet for operation), the lead distance should be <3m.

5. Basic Functions
5-1 Code setting function

Parameter setting code are shown in the below table

| Code setting description | | | | |
|--------------------------|---------------------------------------|---------------|-----------------|--|
| Code | Description | Setting range | Factory default | Remarks |
| F0 | Starting voltage | 30-80% | 40% | Voltage ramp mode works; initial voltage of the current mode is 40% |
| F1 | Soft start time | 2-60s | 16s | Current-limiting mode is invalid. |
| F2 | Soft stop time | 0-60s | 0s | For the model with inbuilt bypass, the soft stop time must be set to 2s. |
| F3 | Starting interval delay | 0-999S | 0s | Use the countdown method for delay, when it is set to 0, there will be no delay and the motor will start immediately |
| F4 | Time delay Programming | 0-999S | 0s | Used in programmable relay output |
| F5 | Starting limiting current | 50-500% | 330% | Current-limiting mode works, maximum current-limiting value of random ramp mode of voltage is 400% |
| F6 | Maximum working current | 50-200% | 100% | Percentage of the rated current of the motor. |
| F7 | Under-voltage protection | 40-90% | 70% | Protection will be provided when the value is below the set value |
| F8 | Overvoltage protection | 100-140% | 120% | Protection will be provided when the value is over the set value |
| F9 | Starting mode | 0-5 | 1 | 0 current limiting 1 voltage, 2 kick current 3.kick+ voltage, 4 current ramp 5 double closed-loop |
| FA | Protection level | 0-4 | 2 | 0 primary 1 light load 2. standard 3.heavy load 4. advanced |
| FB | Control mode | 0-6 | 4 | 0 keyboard, 1 keyboard+ external control 2 external control, 3 external control+ communication 4. keyboard+ external control+ communication, 5 keyboard+ communication,6 communication |
| FC | Allowed parameter modify | 0-2 | 1 | Refer to notes P13: 6-2 for details |
| FD | Communication address | 0-63 | 0 | Used in multi-machine communication between several soft starters and the host computer |
| FE | Programming output | 0-19 | 7 | Run the output (03,04 terminal) setting of the relay |
| FF | Soft stop current-limiting | 20-100% | 80% | Refer to notes P12:12-6 for details |
| FP | Rated current of the motor | | Rated value | Used to input the nominal rated value of the motor |
| FU | Bypass time delay | 0~40S | | |
| FL | Unbalance permit phase loss permit | 0~3 | | 0 unbalance close+ loss-phase close 1 unbalance close+ loss-phase permit 2 unbalance permit+ loss-phase close; 3 unbalance permit+ loss-phase permit |

Note: 1. Maximum operation current of setting entry F6 means the maximum current calculated based on the FP setting, it allows the motor to run continuously, inverse time limit thermal protection will be provided when this value is being exceeded.
 2. In the setting status, if no motion operation is conducted within 2 min, the setting status will be automatically exited.
 3. Parameters can be set in all status except for soft start and soft stop process.
 4. Press YES to get the power on and start the motor will reset the parameters (other than FE) to factory defaults.
 5. Setting entry FL is used in the situation where the soft starter is unable to operate normally due to external interference or damage of mutual inductors in the practical operation, rather than the real unbalance or phase loss.

6. Detailed Description of the Function Selection

6-1 Code FE used in program setting to run the output relay action time

- There're two working methods of programmable relay output function, namely, programmable time sequence output method and programmable status output method. When the setting entry FE is between 0-4 (10-14), the programmable output works in time sequence method to set the starting time.

As shown in the below table:

| Value set by FE | 0 (10) | 1 (11) | 2 (12) | 3 (13) | 4 (14) |
|----------------------------|--------------------------------|------------------------------|----------------------------|----------------------------|------------------------------|
| Output time of programming | When starting command is given | At the beginning of starting | When the bypass is running | When stop command is given | When stop has been completed |

- Under this operation method, there's a 999s timer which is set by setting entry F4. If the value of F4 is not 0, delay will be started according to the initial time set by this setting entry F4.
- Timing until the output status changed. Resetting time of this output will be based on the time set by F4, that is, when the delay is ended, keep the soft starter under the ready status for 1s.
- Control cycle of the programmable time sequence method is a starting process, if the motor is re-started, then the previous programming output process will be automatically suspended and re-started.
- When the setting entry FE is between 5-9(15-19), the programmable output terminal will output according to the set operation status.

As shown in the below table:

| Value set by FE | 5 (15) | 6 (16) | 7 (17) | 8 (18) | 9 (19) |
|----------------------------|--------------|----------------|--------------|------------|--------------|
| Output time of programming | Fault output | Running status | Ready status | RUN status | Start status |

- Programmable status output method is used to indicate the operating status of the soft starter, the factory default 7 of setting entry FE indicates the ready-for-operation status of the soft starter, the motor can be started under this status; the programmable output in fault status indicates the faults of the motor(Err05, Err06, Err07, Err08, Err012, Err15), it is different from the functions of the No.⑤, ⑥ fault output terminals; running status refers to the non-set up fault status which includes the three processes of starting, bypass and soft stop.
- When FE>9, resetting status of the programmable output (No.⑤ ④ external terminals) will be changed from the normally disconnected to connected, namely, inverted output. Using the programmable relay output functions flexibly will simplify the peripheral control logic circuit effectively.

6-2 Code FC's parameter modification permitting function

- Setting entry FC is the parameter modification permitting option, including three types:
 - When the setting entry FC is 0, no parameter can be modified except for the setting entry FC.
 - When the setting entry FC is 1, value of the setting entries F4, F6, FD, FE, FF, FU shall not be modified.
 - When the setting entry FC is 2, value of all setting entries can be modified.

7. Operation Steps

7-1 Modification of the setting parameters

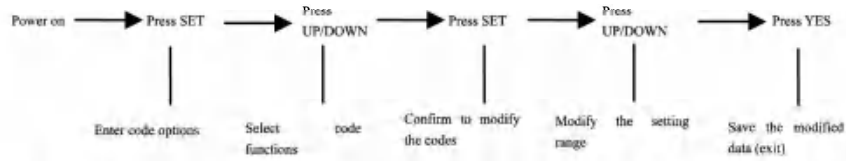

In case of modification, (take the operation control method as external terminal control, that is, the setting of code FB is 2 for example)

| No. | Operation | Display | Remarks |
|-----|------------|--|---|
| 1 | Power on | S:HSY [Ready] status | [Ready] status |
| 2 | Press SET | F0:40% initial voltage | Enter function code options status |
| 3 | Press UP | Fb: 40 control method: buttons are externally connected. | Enter code FE (control method) function options status. |
| 4 | Press SET | Fb:04 control method | Flashing colon indicates the setting range can be modified. |
| 5 | Press Down | Fb:02 control method: external control | Indicates external terminal control |
| 6 | Press YES | Good: data saved successfully | Modified data saved.(exit) [Ready] status, shanghai SHSY |

When operating the keyboard, the internal buzzer of the soft starter will give sound for prompt.

8. Help Information

8-1 Help information and description

| Display | Description |
|------------|---|
| AC:XXXX | Four-digit voltmeter, used to test the voltage of the three phase AC power. |
| XXA-XXV | Indicate the specification of the soft starter |
| H1.Err0r00 | Indicate that the latest fault information is zero |
| H2.Err0r00 | Indicates no occurred fault information |
| H3.Err0r06 | Indicates the occurred fault information Err0r06 |
| ... | ... |
| H9.Err0r00 | Indicates no fault information |
| Ver:4.2 | Indicates the software version of the product is Ver4. 2 |
| LXXXX | The total times of successful starting |
| T-run | Time used in last soft start(whether succeed or not) |

Note: H1-H9 saves the recent 9 fault information in the recursive method

- The help information can be assessed when the soft starter is not in the soft start/ soft stop status or the setting status; press Yes(button for confirmation), then press the up/down buttons to read the prompt messages.
- Press Yes or Stop to exit in the help status.

9. Protection Functions

9-1 Description of protection functions

SJR3 series soft starter possesses complete protection functions to protect the operation security of the soft starter and the motor. During operation, the protection level and protection parameters should be properly set based on different circumstances.

- Over-heating protection of the soft starter: the protection will start when the temperature rises to $80^{\circ}\text{C} \pm 5^{\circ}\text{C}$, and it will stop when the temperature falls to 55°C (lowest).
- Delayed time of input phase loss protection: $<3\text{s}$.
- Delayed time of output phase loss protection: $<3\text{s}$.
- Delayed time of input three-phase unbalance protection: $<3\text{s}$. Taking the deviation of current in each phase is over 50%±10% as the criteria, when the load current is less than 30% of the nominal rated value of the soft starter, it is confirmed that the deviation will increase.
- Protection time of over-current during starting: the protection time shall be continued to be longer than 5 times of the maximum operating current of code F5, see table P16:9-2-1.
- Protection time of overloading in running: inverse time limit thermal protection shall be provided based on the maximum operating current of code F6, see the tripping protection time curve (Figure 9-3-1).
- Delayed time for power under-voltage protection: when the power voltage is under the extreme value 40%, the protection time $< 0.5\text{s}$, when the power voltage is below the set value, the protection time $< 3\text{s}$.
- Delayed time for power overvoltage protection: when the power voltage is over the extreme value 130%, the protection time $< 0.5\text{s}$, when the power voltage is over the set value, the protection time $< 3\text{s}$.
- Delayed time for load short circuit protection $< 0.1\text{s}$, if the current is more than 10 times of the nominal rated value of the soft starter, this protection shall not replace the fuse or short circuit protection device.

The above time parameters are the periods from the valid signal being detected to the tripping protection directive being given; these parameters are for information only. In the event that the protection functions of the soft starter fails to meet the requirements of customers, special protection devices should be installed to ensure the safety.

9-2 Protection function setting

In order to fit different application occasions, there're five protection levels with the SJR2 series soft starters, including 0: Primary, 1: Light load, 2: Standard, 3: Heavy load and, 4: Advanced, all of which are set by the code FA.

- The primary protection inhibits the function of the external instantaneous stop terminal while only retains the overheating, short circuit protection and input phase loss protection during starting, it applies to the occasions when unconditional emergency starting is required, such as fire pump and so on.
- The three protection levels of light load, standard and heavy load all possess complete protection functions with the difference lies in the over-loading thermal protection time curve of the motor. Please refer to table 9-2-1 and figure 9-3-1 for the thermal protection time parameters.
- As for the advanced protection, the protection standard is stricter, while all other protection function parameters are the same as those of the standard protection.

| Set by code FA | | 0 (Primary) | | | 1 Light load | | | 2 Standard | | | 3 Heavy load | | | 4 Advanced | | | Remarks |
|--|----------------------|-------------|---|-----|--------------|-----|-----|------------|-----|-----|--------------|-----|-----|------------|-----|-----|--|
| Protection level of overloading in running | | None | | | Level 2 | | | Level 10 | | | Level 20 | | | Level 10 | | | Based on IEC6 0947-4-2 standard |
| Protection level of over-current in running | | None | | | 3s | | | 15s | | | 30s | | | 15s | | | Calculated as the starting current is more than 5 times of the value set by F6 |
| Tripping time list of overloading in running | Times of the current | 3 | 4 | 5 | 3 | 4 | 5 | 3 | 4 | 5 | 3 | 4 | 5 | 3 | 4 | 5 | Value listed in the table are typical values |
| | Tripping time(s) | 4.5 | 3 | 1.5 | 2.3 | 1.2 | 7.5 | 4.6 | 2.3 | 1.5 | 4.5 | 2.3 | 1.5 | 2.3 | 1.2 | 7.5 | |

- Code FP should be set according to the rated current value on the name plate of the motor; otherwise, relative great deviation will be caused between the starting current and the protection current.
- The motor current set by code FP should not be less than 20% of the nominal current of the soft starter, when the motor current set by code FP is relative low, the sensitivity tolerance of the protection tripping operation will be greater.

9-3 Protection tripping voltage curve

Motor thermal protection tripping time curve based on IEC60947-4-2 standard is shown as follows:

Figure 9-3-1

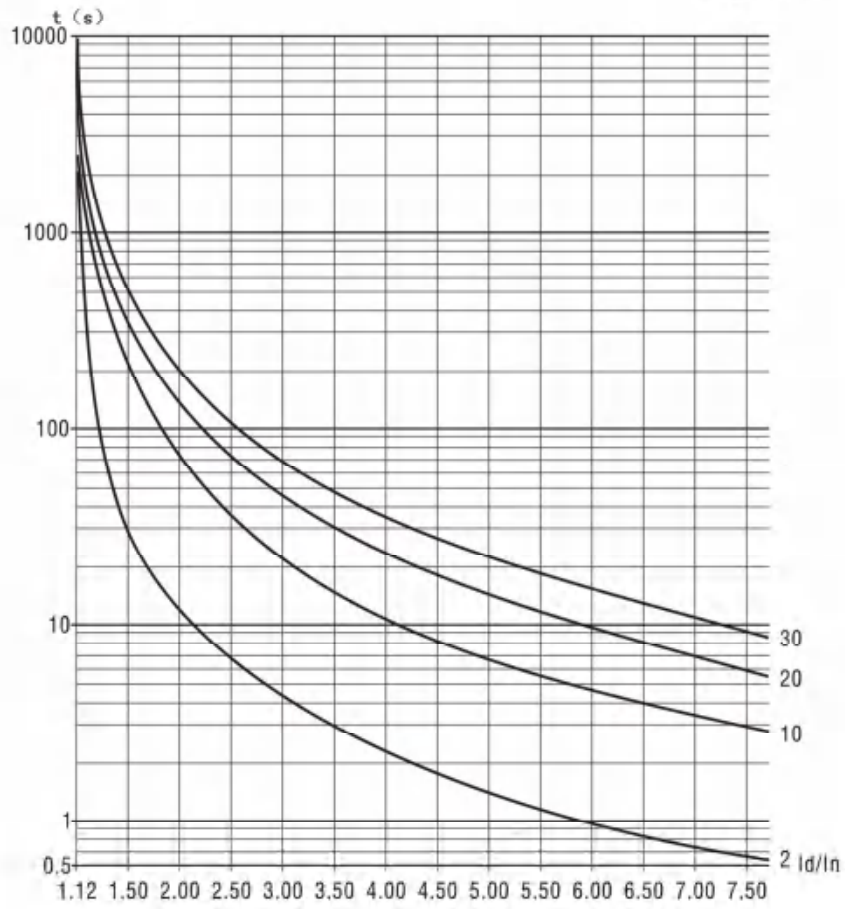

Motor thermal protection tripping time curve (thermal status)

10. Operated Protection

10-1 List of protective actions

In case of any exception with the soft starter, the protection function will act for tripping immediately. Please refer to remarks of table 10-1-1 for alarm description displayed in the LED and related contents.

| Display | Description | Problems and Solution |
|---------|---|---|
| Err00 | Faults are removed | There've just been under-voltage, overvoltage or overheating, instantaneous stop terminal disconnection and other faults which are removed now. |
| Err01 | External instantaneous stop terminal opens circuit | Connect the external instantaneous terminal ^① to the common terminal ^② in short circuit, or connect such terminal to the normally closed contact point of other protection devices. |
| Err02 | The soft starter is Overheating | starting too frequently or the power of the motor not matching the soft starter. |
| Err03 | Starting time is more than 60s. | Improperly set starting parameter or too heavy load or insufficient power supply capacity. |
| Err04 | Input open-phase | Check if there's any fault with the input or the main circuit, or if the inbuilt bypass contactor is jammed in the close position or if the SCR is disconnected. |
| Err05 | Output open-phase | Check if there's any fault with the input or the main circuit, or if the inbuilt bypass contactor is jammed in the close position or if the SCR is disconnected. |
| Err06 | Three-phase unbalance | Check for any exception with the input three-phase power supply or the load motor. |
| Err07 | Start over-current | Check if the load is too heavy or the power of the motor not matching the soft starter. |
| Err08 | Overload protection during running | Check if the load is too heavy or if the parameters of setting entries F6, FP are improperly set. |
| Err09 | Voltage of the power supply is too low | Check the input power supply voltage or if the parameter of setting entry F7 is improperly set. |
| Err10 | Voltage of the power supply is too high | Check the input power supply voltage or if the parameter of setting entry F7 is improperly set. |
| Err11 | Error with the parameter setting | Modify the setting or press Yes to get the power on and start the soft starter to reset the parameters to factory defaults. |
| Err12 | Load short-circuit | Check if the load or SCR is short-circuited or if the load is too heavy. |
| Err13 | Automatic restart. The connection is error | Check if the external control starting and stop end is connected to the two-wire mode or not. |
| Err14 | The connection of external stopping terminal is error | When external control is permitted, the external control terminal is disconnected, so the motor can't get started. |
| Err15 | Under loading of the motor | Check if any fault with the motor spindle or the load. |

Note: some faults are related to each other, e.g. Err02 overheating of the soft starter may be related to over-current during starting or load short-circuited. Therefore, it is necessary to consider comprehensively while finding out the fault to determine the fault point accurately.

Note: when the motor stops running again after successfully started by the soft starter, it indicates that such stop is caused by close failure of the bypass contactor, please check if there's any mistake or poor contact with the inbuilt bypass contactor or relevant connection.

11. Troubleshooting

11-1 Problems and solutions

| Fault | Content | Solutions |
|---|--|---|
| | If any abnormal power line is connected to the input terminals (R, S, T) | Please wire correctly and switch on, then switch off and switch on again |
| The motor does not rotate | If the inbuilt bypass contactor runs normally | Check the connection of the inbuilt bypass contactor, check if it closes or not in the running status, check the coil connection of the inbuilt bypass contactor |
| | If any abnormal display in the keyboard | Please refer to the "List of Protective actions" in P18. |
| | If the motor is locked (if the load is too heavy) | Please unlock the motor (reduce the load) |
| Keyboard is failed to be started | If disconnection of terminal 07, 10 are displayed on the keyboard or if the code FB is set correctly | No: if the power supply has phase loss, check the power input Yes: if 10 and 07, 08 are disconnected, check the external connection of terminals Set code FB correctly |
| The external control cannot be started | If the code FB is set to external control | Check if terminals 10 and 07, 08 are disconnected, check the external connection, check if code FB is set to the external control or not, if no, set it correctly |
| The motor rotates but the speed stays the same | If the load is too heavy | Please reduce the load Increase the initial voltage or starting current |
| The starting time is too long | If the load is too heavy, if the code is set correctly or if the motor specification is normal | Please reduce the load Please set F0 (starting voltage), F5 (limiting current at start) |
| The starting time is too short | Time for starting with load is too short | The starting time is below the set value when the load is light, and it will be normal if it starts evenly, set code F1 starting time (invalid under current mode) |
| The motor comes to a sudden stop during running | Check the external input terminal | Check if the connection wires of terminals 07 and 10 become loose or not. If external protector is connected, please check if the normally closed point operates or if the connection wire of the external stop button become loose or not. |

12. Starting Mode

12-1 Current limiting starting mode

- a) The soft starter will be under current starting mode when code F9 is set to 0 (current limiting). Figure 12-1 shows the current change wave of the motor under the current limiting mode. I_1 is the set starting current limiting value, when the motor starts, the output voltage will increase rapidly until the current of the motor reaches the set current limiting value I_1 , and the current of the motor will be kept under such value, then with the increasing of the output voltage, the motor will speed up gradually, and when the motor reaches the rated rotation speed, the bypass contact will close, the output current will drop rapidly to the rated current $1.1I_e$ of the motor or less, and the whole starting process completes.
- b) When the load of the motor is relatively light or the set current limiting value is relatively high, it will be normal that the maximum current may not reach the set current limiting value. Generally, current limiting starting mode applies to the occasions where there're strict limiting requirements on starting current.

Figure 12-1-1



12-2 Voltage ramp starting

- a) The soft starter will be under voltage starting mode when code F9 is set to 1 (voltage). Figure 12-2-1 shows the output voltage wave of the output ramp starting. U_1 is the starting voltage value at start, when the motor starts, if the current of the motor is within the range of the rated value 400%, the output voltage of the soft starter will increase to U_1 rapidly, then the starting parameter set according to the output voltage will rise gradually, and the motor will accelerate smoothly with the rising of the voltage and reach the rated rotation speed when the voltage reaches the rated voltage U_e , then the built bypass contactor will close and the whole starting process completes.
- b) Starting time: t is the control parameter calculated from the standard testing condition based on standard load. Taking this parameter as the criteria, the SJR2 series soft starter enables the motor accelerate smoothly through controlling the output voltage to complete the starting process. This parameter is not the mechanical control time t which has nothing to do with if the motor accelerates smoothly or not. Given this, when the load is relatively light, the starting time will be less than the set starting time, and it will be normal as long as the starting process completes smoothly. Generally, the voltage ramp starting mode applies to the occasions where high requirements are not placed in the starting current but in the starting smoothness.

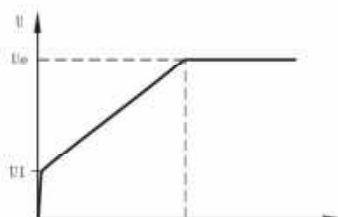

Figure 12-2-1

12-3 Kick mode

- a) The soft starter will be under kick starting mode when code F9 is set to 2(kick+ current limiting) or 3(kick + voltage). Figure 12-3-1 and 12-3-2 show the output change wave of the kick starting mode. In some occasions with heavy load, this starting mode can be used when the motor fails to be started due to effect of the mechanical static friction force. During start, apply a relatively high fixed voltage to the motor for a limited period to overcome the static friction force of the motor load to rotate the motor, then the motor will be started in the current limiting or fixed voltage ramp method.
- b) Before using this mode, the motor shall be started through the non-kick mode, and this mode shall be only used when the motor fails to rotate due to high friction, otherwise, starting with this mode shall not be used to reduce the unnecessary shock caused by large current.

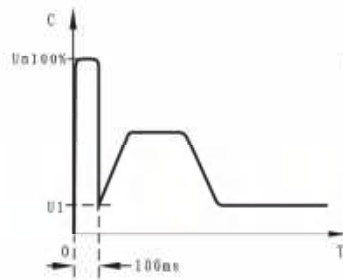

Figure 12-3-1

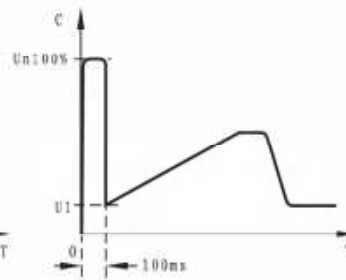

Figure 12-3-2

12-4 Current ramp starting mode

- a) The motor will be under current starting mode when code F9 is set to 4(current ramp). Figure 12-4-1 shows the output current wave of the current ramp starting mode, t_1 is the time value set by code F1.
- b) The current ramp starting mode possesses strong accelerating capacity, when used in bipolar motor, it can shorten the starting time to a certain extent.

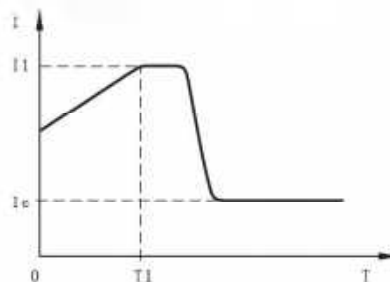

Figure 12-4-1

12-5 Voltage and current limiting double closed-loop starting

- a) The motor will be under double closed-loop starting mode when code F9 is set to 5(double closed loop). The voltage and current limiting closed-loop starting mode which adopts the double closed-loop control of voltage ramp and current limiting is a comprehensive starting mode requires both smooth starting and strict current limiting. It employs the prediction algorithm which estimates the operation status of the motor
- b) Output voltage wave of this starting mode varies with the motors and loadings.

12-6 Soft stop

There're two types of stop mode for SJR2 series soft starter, namely, soft stop mode and free stop mode.

- a) The soft starter will be under soft stop mode when code F2 is not set to 0. Figure 12-6-1 shows the output current wave of the soft stop mode. T is the soft stop time set by the code F2. Under this stop mode, power supply of the motor will be switched to thyristor output of the soft starter through the inbuilt bypass contactor, and the output voltage of the soft starter will gradually drop from the full voltage to enable the rotation speed of the motor reduce smoothly to avoid mechanical shock until the motor stops running. The output cut-off voltage during soft start shall be equal to the starting voltage during start.
- b) The soft stop mode can reduce and even eliminate surge of load of pumps and reduce the large current shock during soft stop. The soft stop current limiting value is the percentage calculated from the starting current limiting.

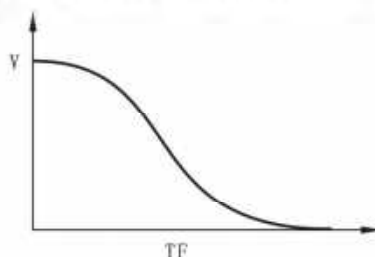

Figure 12-6-1

12-7 Free stop

- a) The soft starter will be under free stop mode when code F2 is set to 0(free stop). Under this type of stop mode, upon receiving the command, the soft starter will disconnect the inbuilt bypass contactor immediately and prohibit the voltage output of the thyristor of the soft starter, and then the motor will gradually stop due to load inertia. The code can be set to this mode when the soft starter is under the one-to-N connection method to avoid the phase loss fault alarm during output switching.
- b) Generally, in order to prolong the service life of the soft starter, free stop mode should be selected if there's no necessary for soft stop. The free stop mode fully inhibits instantaneous output and thus it can prevent the instantaneous large current shock in the special application occasions.

There are six different starting modes with the SJR3-3000 series soft starters which apply to various complicated motors and loading situations, among which users can select according to different application ranges.

13. External Dimensions

13-1 External dimensions of 5.5kw-75kw

Please see the below table for the external and installation dimensions of SJR3-3000 series 5.5kw-75kw soft starter.

Table13-1-1

| Model | Rated power (KW) | Rated current (A) | External dimensions | | | Installation dimensions | | | Net weight (kg) |
|-------------|------------------|-------------------|---------------------|-----|-----|-------------------------|-----|----|-----------------|
| | | | H1 | W1 | D | H2 | W2 | d | |
| SJR3-3005.5 | 5.5 | 11 | 310 | 155 | 175 | 296 | 128 | M6 | <5 |
| SJR3-3007.5 | 7.5 | 15 | 310 | 155 | 176 | 296 | 128 | M6 | <5 |
| SJR3-3011 | 11 | 22 | 310 | 155 | 176 | 296 | 128 | M6 | <5 |
| SJR3-3013 | 15 | 30 | 310 | 155 | 176 | 296 | 128 | M6 | <5 |
| SJR3-3018 | 18.5 | 37 | 310 | 155 | 176 | 296 | 128 | M6 | <5 |
| SJR3-3022 | 22 | 43 | 310 | 155 | 176 | 296 | 128 | M6 | <5 |
| SJR3-3030 | 30 | 60 | 310 | 155 | 176 | 296 | 128 | M6 | <5 |
| SJR3-3037 | 37 | 75 | 310 | 155 | 176 | 296 | 128 | M6 | <5 |
| SJR3-3045 | 45 | 90 | 310 | 155 | 176 | 296 | 128 | M6 | <5 |
| SJR3-3055 | 55 | 110 | 310 | 155 | 176 | 296 | 128 | M6 | <5 |
| SJR3-3075 | 75 | 150 | 310 | 155 | 176 | 296 | 128 | M6 | <5 |

- Rated power and rated current refer to the maximum rated values of the soft starter. Generally, corresponding parameters of the adaption motor shall not be greater than these values.
- Considering economic and applicable using, we made the 75kw types into large and small ones, under heavy load, the large one should be selected as table (13-2-1), and heavy load should be marked.

13-2 External dimensions of 75kw-600kw

Please see the below table for the external and installation dimensions of SJR3-3000 series 75kw-600kw soft starter.

Table 13-2-1

| Model | Rated power (KW) | Rated current (A) | External dimensions | | | Installation dimensions | | | Net weight (kg) |
|-----------|------------------|-------------------|---------------------|-----|-----|-------------------------|-----|----|-----------------|
| | | | H1 | W1 | D | H2 | W2 | d | |
| SJR3-3075 | 75 | 150 | 585 | 265 | 240 | 490 | 235 | M8 | ≈27 |
| SJR3-3090 | 90 | 160 | 585 | 265 | 240 | 490 | 235 | M8 | ≈27 |
| SJR3-3115 | 115 | 200 | 585 | 265 | 240 | 490 | 235 | M8 | ≈27 |
| SJR3-3132 | 132 | 250 | 585 | 265 | 240 | 490 | 235 | M8 | ≈27 |
| SJR3-3160 | 160 | 300 | 585 | 265 | 240 | 490 | 235 | M8 | ≈27 |
| SJR3-3200 | 200 | 360 | 585 | 265 | 240 | 490 | 235 | M8 | ≈27 |

- Rated power and rated current refer to the maximum rated values of the soft starter. Generally, corresponding parameters of the adaption motor shall not be greater than these values.

14. Application Range

14-1 types of application load

SJR3-3000 soft starter can meet the requirements of most driving heavy load; the table below is for reference only.

| Types of application load | Ramp time for starting(s) | Ramp time for stop (s) | Initial voltage (%) | Voltage starting (maximum current limiting value) | Current limiting starting |
|---------------------------|---------------------------|------------------------|---------------------|---|---------------------------|
| Centrifugal pump | 16 | 20 | 40 | 4 | 2.5 |
| Ball grinder | 20 | 6 | 60 | 4 | 3.5 |
| Fan | 26 | 4 | 30 | 4 | 3.5 |
| Light-load motor | 16 | 2 | 30 | 4 | 3 |
| Piston compressor | 16 | 4 | 40 | 4 | 3 |
| Lifting machine | 6 | 10 | 60 | 4 | 3.5 |
| Blender | 16 | 2 | 50 | 4 | 3 |
| Crusher | 16 | 10 | 50 | 4 | 3.5 |
| Screw compressor | 16 | 2 | 40 | 4 | 3 |
| Spiral conveyor belt | 20 | 10 | 40 | 4 | 2 |
| Screw conveyor | 20 | 10 | 40 | 4 | 2.5 |
| Heat pump | 16 | 20 | 40 | 4 | 3 |

15. RS485 Communication

Through the inbuilt RS485 standard interface, the SJR3-3000 series soft starter can connect with PC and PLC and other hosts to conduct serial communication. The command of the host can control running or stop of the soft starter, monitor the running status of the soft starter and modify its functional data. Please refer to RS485 operation instructions for the detailed information of the communication. Remote operation, running command input, running status management, write-once of functional data of several soft starters can be conducted by means of the RS485 communication through computers to implement simplified operation during function codes input.

Major functions

1. Input of stop running command.
2. Monitoring of the running status
3. Real-time tracking (tabular display of the running information)
4. Read-once, write-once and saving to files of function codes. Please consult our company separately for the communication software.

15-1 MODBUS communication protocol

15.1 Overview about Modbus RTU communication protocol

Modbus is a kind of serial asynchronous communication protocol with RS485 as the physical interface. Being designed for Modicon PLC, it has the structural features of PLC. In network control, it can read and write the SJR2-3000 as if it were a PLC. It can project the start and stop control, status information (current, fault etc.) and function parameters to the holding register (4XXX). Its read and write control shall be conducted through the PL master station.

15.1.1 Electrical interface

RS485 half duplex

Communication parameters: baud rate: 9600; 8 data bits; no check digit; 1 stop bit.

15.1.2 Format of the communication data:

Data format:

| ID bit | Function code | Data zone | QRC verification |
|--------|---------------|-----------|------------------|
| 1 byte | 1 byte | N bytes | 2 bytes |

15-2 related settings of the soft starter

15.2.1 Address of the register

| Address of the register | Operation code | Function specification of the register |
|-------------------------|----------------|--|
| 4001 | 06 | Control word |
| 4002 | 03 | Status word |
| 4003 | 03 | Mean value of current*10 |
| 4004 | 03 | Fault code |
| 40256-40274 | 03&06 | Function code of the soft starter |

(1) Registers not listed above shall be illegal and shall not be written or read; otherwise the slave station will report an exception code to the controller.

(2) All data addresses are based on 40000, that is, the address of the coil relay is 0001 and address of 402567is 0100(hexadecimal)

15.2.2 Supported codes

The soft starter supports the following codes only, and exception code 01 will be reported if other codes are used.

| Code | 03 | 06 |
|----------------------|-------------------|---------------------------|
| Function description | Read the register | Write the single register |

Code 03 shall be read through WORD only

15.2.3 Description of the register

40001 command register

| Bit | Value | Description |
|------|-------|------------------------|
| 0 | 1 | Soft starter starts |
| | 0 | Keep the status |
| 1 | 1 | The soft starter stops |
| | 0 | Keep the status |
| 2 | 0-1 | Reset the soft starter |
| 3-15 | 0 | Not used |

For example, to start the soft starter form the slave station address 02, the controller will send 02 06 00 01 00 01, if the command is executed normally, code 02 06 00 01 00 01 will be returned. Whether the soft starter can start normally or not shall further be based on the status register. If there's any fault, send 02 06 00 01 00 04 to reset it.

Status register of register address 40002

The status register reflects the status of the soft starter; it is represented by one word.

| Bit | Value | Description |
|------|-------|------------------|
| 0 | 1 | Starting status |
| | 0 | Stop status |
| 1 | 1 | Running status |
| | 0 | Stop status |
| 2 | 1 | Soft stop status |
| | 0 | Stop status |
| 3 | 1 | Fault status |
| | 0 | Normal status |
| 4-15 | | Not used |

E.g. Read the status register codes 02 03 00 02 00 01

If the starter is in the process of starting, codes 02 03 00 02 00 01 will be returned.

If any fault with the starter, codes 02 03 00 02 00 08 will be returned, and types of fault can be read according to 4.

40003 mean value of current (hexadecimal)

The value projects the three-phase actual mean value of current*10(including a decimal number)

E.g. Read the current value

Send codes 02 03 00 02 00 01

If the current is 235 A, codes 02 03 02 09 2E will be returned (actual current value shall be the returned value/10)

40004 fault codes (hexadecimal)

When the third number in status register is 1, it represents that the soft starter is in fault status. The fault codes shall be the same as those in 6.1

E.g.: send codes 02 03 00 04 00 01

If 02 03 02 00 04 are returned, it indicates the current input phase loss (fault code 04)

Function parameters register 40XXX of the soft starter

40256-40274 are function registers, the corresponding address are 0X0100-0X0112, the high byte address is 01, the low byte address are 0X00-0X12, the corresponding function codes are F0-FL, consistent with the function code table 4.2. For example, address 0X109 is corresponding to function code F9 (starting mode). These codes can be written and read. The usages are illustrated respectively:

Example 1 Read the value of function code F5 (current limiting value)

Send codes 02 03 01 05 00 01

The returned read value of F5 function code 02 03 02 01 5 E indicates the current limiting value is 350%

Example 2 Read function code FA (protection level)

Send codes 02 03 01 0A 00 01

The returned read value of FA function code 02 03 02 00 03 indicates the protection level is 3.

Example 3 Change the function code 05(starting current) of the soft starter to 250%

The host sends the codes 02 06 01 05 00 FA, the soft starter returns the codes 02 06 01 05 00 FA.

If codes 02 86 03 are returned, it indicates that writing failure, maybe the starter is running.

15-3 Exception response

| Code | Description | Remarks |
|------|----------------------|---|
| 02 | Illegal function | The function code cannot be executed, as it is not supported by the soft starter. |
| 02 | Illegal data address | The data address received cannot be executed, as the address is out of range. |
| 03 | Illegal data value | The data received cannot be executed, as 1. The parameter is beyond the amplitude limiting 2. The parameter cannot be modified 3. The parameter cannot be modified as the soft starter is running. |

15.3.1 Illegal function code 01

Format of the master station inquiry message:

| Substation address | Function code | High byte of the initial address | Low byte of the initial address | Upper bit of the number of registers | Lower bit of the number of registers | CRC Verification |
|--------------------|---------------|----------------------------------|---------------------------------|--------------------------------------|--------------------------------------|------------------|
| 0x01 | 0x08 | 0x00 | 0x80 | 0x00 | 0x0D | |

As 0 x 80 function code is not used in the protocol, so for the substation response:

| Substation address | Function code | Exception code | CRC verification |
|--------------------|---------------|----------------|------------------|
| 0x01 | 0x88 | 0x01 | |

15.3.2 Illegal data address 02

Format of the master station inquiry message

| Substation address | Function code | High byte of the initial address | Low byte of the initial address | Upper bit of the number of registers | Lower bit of the number of registers | CRC Verification |
|--------------------|---------------|----------------------------------|---------------------------------|--------------------------------------|--------------------------------------|------------------|
| 0x01 | 0x04 | 0x01 | 0x80 | 0x00 | 0x07 | |

As register address of the 04 function code is incorrect, so for the substation response:

| Substation address | Function code | Exception code | CRC verification |
|--------------------|---------------|----------------|------------------|
| 0x01 | 0x84 | 0x02 | |

15.3.3 Illegal data value 03

Format of the master station inquiry message

| Substation address | Function code | High byte of the initial address | Low byte of the initial address | Upper bit of the number of registers | Lower bit of the number of registers | CRC Verification |
|--------------------|---------------|----------------------------------|---------------------------------|--------------------------------------|--------------------------------------|------------------|
| 0x01 | 0x04 | 0x00 | 0x80 | 0x01 | 0x08 | |

Number of registers of function code 04 is incorrect, so for the substation response:

| Substation address | Function code | Exception code | CRC verification |
|--------------------|---------------|----------------|------------------|
| 0x01 | 0x84 | 0x03 | |

15-4 Notes for use

- (1) The communication address, communication rate and verification mode must be the same as the communication settings of the controller.
- (2) If no response data is received, please check the above parameter settings; check if the connection to 485 terminals is correct and if the CRC verification is correct.
- (3) In the event of communication among several TGS5, 120Ω resistances should be connected at both AB ends of the last TGS5.

(4) When connected to other Modbus equipments, connection should be conducted as per the diagram below:

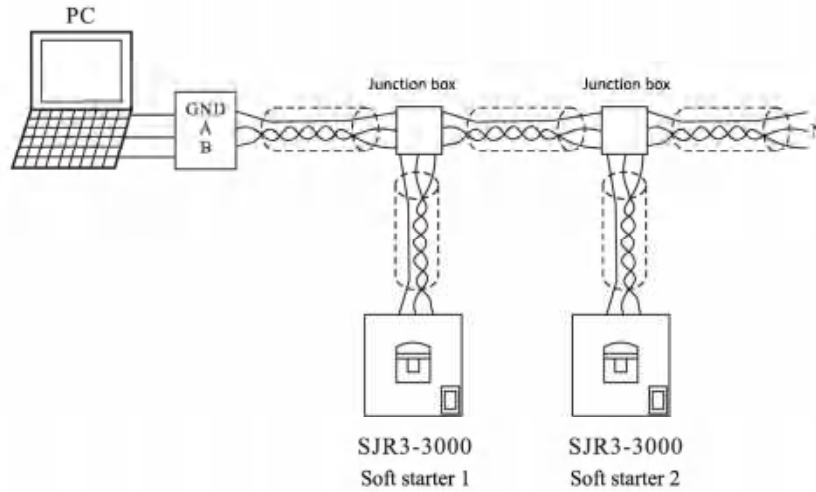

Special Tips:

All soft starting products are of device types in case of delivery. In order to make it convenient for installation and debugging of the set manufactures, the output protection of the device-type soft starter has been set as "standard" when delivery. In installation and debugging, the set manufacturer can directly use a small motor or use three lamps to form a star to work as the load, then starting, stop, control and other operations can be conducted. However, in practical application, please be sure to change the output protection to "advanced", and then the soft starter will possess the complete protection functions for phase loss, three-phase unbalance, over-current, overloading and so on. (Note: If the soft starter is reset to factory defaults, the output protection will be reset to "standard" again, so it will be necessary to set the protection level to "advanced" again). Please kindly note this.

16. Annex

Warranty and After-sale Services

Thanks for purchasing the soft starter manufactured by SHUEN. The product is made under a perfect quality management system. For your convenience, we hereby give the following instructions with regard to the warranty and after-sale services:

1. Warranty

Warranty of the product shall be 12months from the purchasing date or 24 months from the manufacturing date recorded on the name plate, whichever is shorter. However, for any fault caused by the following reasons, regardless it is within the warranty or not, the repair shall be charged.

- 1) Incorrect use, unauthorized modification or improper repair;
- 2) Using beyond the standard specification requirements;
- 3) Damage caused by falling or occurred during shipping;
- 4) Earthquake, fire, wind disaster, lightning stroke, abnormal voltage, other Acts of God and secondary disasters.

2. After-sale services

- 1) If the soft starter fails to run in good status, please check first, and then check again by re-reading and referencing this instruction manual.
- 2) For any fault, please contact with the reseller or the "after-sale services department, office of our company" recorded in the instruction manual.
- 3) Repair within the warranty: free repair will be provided for any fault caused by the problems of manufacturing. However, all items in the "SHUEN Starter Warranty Certificate" should be filled correctly and detailedly, otherwise, the repair will be charged.
- 4) Warranty expired: under the circumstance that the functions can be maintained after repair, paid repair will be provided as required by customers.

3. Service commitments

- 1) With regard to SJR3 series soft starter under 75kw (included): for any damage caused by non-artificial reasons within one year after purchasing, replacement will be provided. In the case of those ones over 75kw, for any damage caused by non-artificial reasons within one year after purchasing, repair will be provided, and upon expiration of such one-year, paid technical service will be provided.
- 2) For technical support on using and operation of the soft starter: at the initial stage of using, our company will arrange technical service personnel to conduct debugging and installation on the site of customers and provide related technicians to support customer training with no charge.
- 3) We will response to the technical service and maintenance service requirements of customers in telephone within 24 hours upon receiving such requirements.
- 4) Upon receiving the debugging request of customers, if through transportation is available, we will arrive at the site of customer within 48 hours; for the area with traffic inconvenience, we will arrive at the site within 72 hours.

SHUEN Soft Starters Warranty Certificate

| | | | | | | |
|---------------------------|--------|----|-------------------|--|-----|--|
| Customer | | | Person in charge | | Tel | |
| Customer address | | | | | Fax | |
| Mode | SJR3-3 | KW | Manufacturing No. | | | |
| Store name for purchasing | | | Purchasing date: | | | |
| Address of the store | | | Date of fault | | | |

Fault condition

| | | | | | | |
|----------------------------|---------------------------|---|--------------------------------------|-----------------|--------------------|--------------------|
| Usage | | | Motor | KW | polar(s) | model |
| Occurrence time | During continuous running | | in accelerating | in decelerating | during power input | other |
| Display of occurrence time | Alarm display | Keyboard display or not | Output voltage (Yes No) | | | |
| Running after resetting | Yes No | method of resetting | keyboard panel terminal | power supply | other | |
| Control terminals used | 01, 02 | 03, 04 | 05, 06 | 07 | 08 | 09 10 11, 12 Other |
| Operation time | | | Frequency for finding out such fault | / | Installation site | |
| Power cut | Yes No | Any abnormality with the surrounding machines | | | Historical fault | Yes (___times) No |



China Technical Service Headquarter
Manufacturer: SHANGHAI SHUEN ELECTRICAL TECHNOLOGY CO., LTD.
Address: Shanghai Guanghua Road Songjiang District 488 Lane 2,
Tel: 4009-700-339
Fax: 021-51685157
Postal code: 201600
Website: [Http: //www.shuen.com.cn](http://www.shuen.com.cn)

The technical parameters are subject to change without notices.
All rights reserved.
Figures herein are for information only.